

OPERATION MANUAL OF  
TYPE SE 350 TON CASING ELEVATORS/SPIDER  
(VERSION OF 2010-06)

- OUR CORPORATION HAS PASSED ATTESTAION OF API Spec 8A/8C  
ELEVATOR ACCREDIT NO.: *API Spec 8A – 0056, 8C-0068*
  
- OUR CORPORATION HAS PASSED ATTESTAION OF ISO9001-2008  
QUALITY SYSTEM  
CERTIFICATE NO.: *01410Q10448R4M*

# Table of Contents

<b>I 、 General</b> -----	<b>1</b>
A. Introduction-----	1
B. Operation-----	1
<b>II 、 Main Technical Parameters</b> -----	<b>2</b>
<b>III、 Installation</b> -----	<b>4</b>
A. Installing Elevator/Spider -----	4
B. Connecting Air Lines-----	4
C. Removing and Replacing Slip Segments-----	5
D. Removing and Installing Guides-----	6
<b>IV、 Operation</b> -----	<b>6</b>
<b>V 、 Lubrication</b> -----	<b>7</b>
<b>VI、 Maintenance</b> -----	<b>8</b>
A. Preventive Maintenance-----	8
B. Troubleshooting-----	8
C. Transportation and Storage -----	9
<b>VII、 Parts List</b> -----	<b>10~20</b>
<b>VIII、 Client Opinion</b> -----	<b>21</b>

## I 、 General

### A. Introduction

The 350 and 500 Ton Casing Elevator/Spider Units are pneumatically operated power tools, capable of handling casing sizes from 4.1/2 to 24.1/2 inches, with string loads of 3150kN(700,000 pounds) for the 350 ton unit and 4500kN(1,000,000 pounds) for the 500 ton unit.

These units have been refined and incorporate such engineering features as air powered operation with safety latch, and four independent slips, as standard equipment.

The main bodies can be dressed as a casing elevator or spider. The elevator consists of an upper unit using a bell guide and bottom guide. The lower unit is dressed as a Spider with a top guide that centers the Spider over the master bushing.

The elevator is attached to the derrick traveling block and hook with 350 or 500 ton standard API links. The Spider locates directly on the pin drive master bushing (27.1/2 MSPC, 37.1/2 and 49.1/2 MPCH), and square drive master bushing (27.1/2 MSS), and will accommodate any other master bushing when used with an Adapter Plate of our company.

### B. Operation

The Elevator/Spider operates from a single, 2 position control lever that raises and lowers the slips. The slips are suspended on two inter-locking leveling beams that are driven by four air cylinders. This feature allows the slips to operate in synchronization in both the set and raised positions, while permitting the cylinders to work together so no one cylinder overrides any other, causing misalignment and binding. A manual override system is also provided in the event of a temporary loss of rig air pressure.

The pneumatic system incorporates a filter-regulator, which regulates and filters the rig air and reduces the pressure to the requirements of the Elevator /Spider system. This filtered, regulated air pressure is then sent to the lubricator

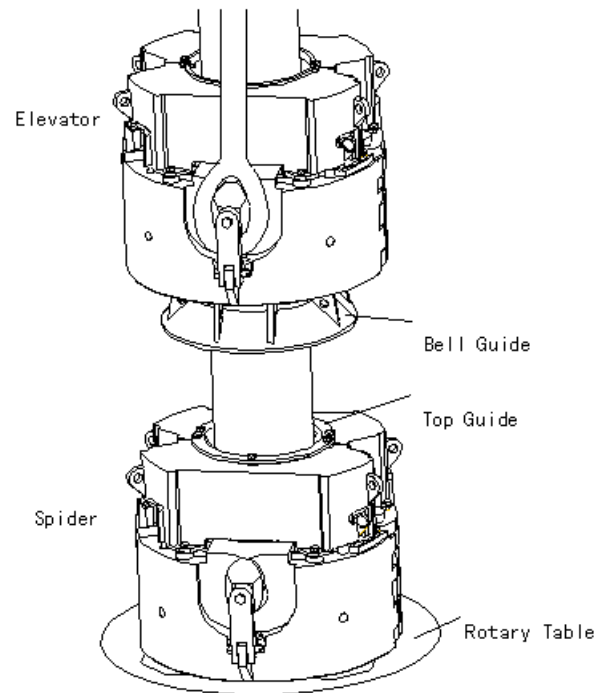

Figure 1-1

(mounted on the Elevator and Spider) to add a small amount of oil mist to lubricate the four drive cylinders. The air from the lubricator is sent to the control valve that operates the leveling beams. As directed by the control lever, the air cylinder will raise or lower the slips attached to the leveling beam.

The direct air lift and lock mechanism enables instant actuation of the slips. In offshore or land operations this allows the derrick man or the men on the floor to raise and lock the slips, or lower the slips in the elevator or spider instantly.

## II、 Main Technical Parameters

Table 1

Item \ Spec	500		350	
style	14	24.1/2	14	20
Casing Size-range	4.1/2 ~ 14	16 ~24.1/2	4.1/2 ~14	16 ~ 20
Normal Operating Pressure	0.6 ~ 0.8MPa			
Maximum Pressure	1 MPa			

Table 2

Unit Height	500		350	
	4.1/2 ~ 14	4.1/2 ~ 24.1/2	4.1/2 ~ 14	16 ~ 20
Elevator with Bell Guide (Less Guide and Slip Assy.)	1,941	4,150	1,634	2,200
Spider (Less Guide and Slip Assy.)	1,850	3,900	1,543	2,000

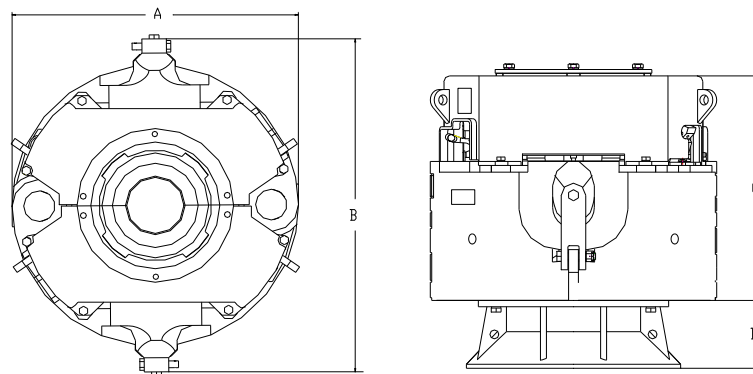

Figure 2-1

Table 3

Unit Height	Metric (cm)			
	500		350	
	14	24.1/2	14	20
Elevator with Bell Guide	109.2	116	96.5	96.5
Spider with Guide	94	103	81	81
Bell Guide	25.4	16.5	25.4	25.4
Unit Diameter (Max.)	127.5	160	107.9	120.7

Table 5

Casing Size(in)	Slip Body Size	Inserts	Number		Beveled Inserts	Number
			500T	350T		
4.1/2	5.1/2	2168	32	24	2168B	16
5		2169	32	24	2169B	16
5.1/2		2170	48	40		
5.3/4	5.3/4		48	40		
6.5/8	7.5/8	2632	48	36	2632B	24
7		2623	48	36	2623B	24
7.5/8		2633	72	60		
7.3/4		2649	72	60		
8.5/8	9.5/8	2640	64	48	2640B	32
8.3/4		2650	64	48	2650B	32
9.5/8		2633	96	80		
9.3/4		2649	96	80		
9.7/8		2649	96	80		
10.3/4	11.3/4	2640	80	60	2640B	40
10.7/8		2650	80	60	2650B	40
11.3/4		2637	120	100		
11.7/8		2651	120	100		
13.3/8	14	2636	80	60	2636B	40
13.1/2		2652	80	60	2652B	40
13.5/8		2653	80	60	2653B	40
13.3/4		2655	80	60	2655B	40
14		2635	120	100		
16	16	001605327	144	120	16	
18	18.5/8	18.5/8×18	120	84	001605336—28B I	30 (350T-28)
					001605337—28B II	30 (350T-28)
18.5/8		001605327	180	140		
20	20	001605327	180	140		
22	22	001605327	216			
24	24	001605327	216			
24.1/2	24.1/2	001605327	216			

Note: Numbers followed by the letter "B" indicate beveled inserts,

### III、 Installation

The 350 and 500 Ton Elevator/Spider Units are shipped as illustrated in Figure 1-1. A specified set of slip segments and guide rings are shipped installed.

#### A. Installing Elevator/Spider

A typical installation is shown in Figures 1-1 and 3-1.

1. If replacing slips and or guides refer to paragraph III---C and III---D

#### Note

Slip segments and guide rings must be the same size or damage to pipe and slips will result.

2. If opening of rotary table is less than 20.1/2 " I.D., (with bushing removed). Install the adaptor plate on the top of rotary table.
3. Place spider in position on master bushing and secure in place with chain back-up.
4. Attach links to Elevator as indicated in Figure 1-1, placing link eyes on Elevator hook ears and secure in place.
5. Lubricate Elevator/Spider as indicated in Table 6.
6. Proceed to connect air lines.

#### B. Connecting Air Lines

1. Refer to Figure 3-1 for typical installation.
2. Mount regulator-filter at a location on derrick which will provide adequate length for air line hook-up.
3. Attach a 50 foot, 1/2" air line between Elevator and the Stand Pipe located 45 feet above the rig floor, near the derrick stabbing board. Both ends of air lines are quick disconnecting type.
4. Attach a 25 foot 1/2" air line between Spider and regulator-filter.
5. Attach rig airline to regulator-filter and adjust regulator to 70 to 90 psig.

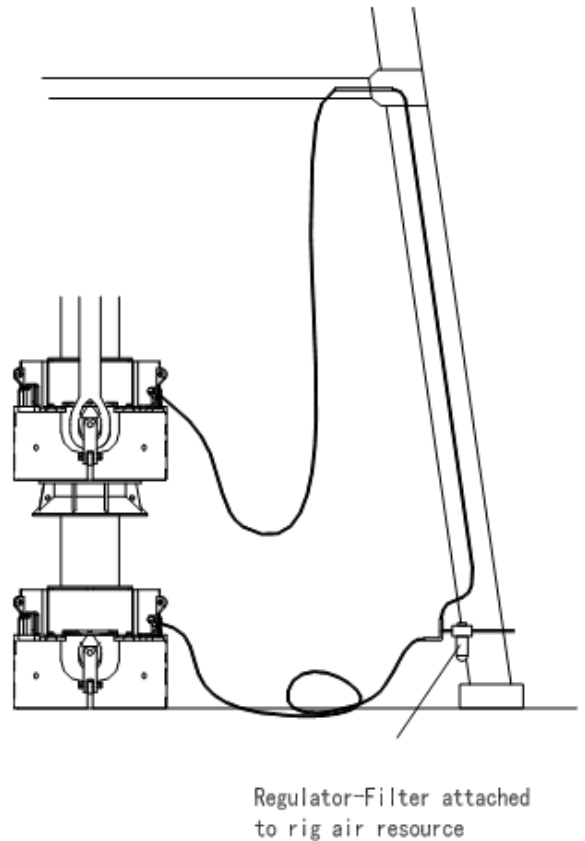

Figure 3-1

6. Check operation of Elevator/Spider, as indicated in Section IV.

**Note**

If tools will not remain permanently with rig, use two 50 foot air lines. Tie one 50 foot section of hose 45 feet above floor near casing stabber. Attach second section of hose to first hose with the other end to Elevator.

**C. Removing and Replacing Slip Segments**

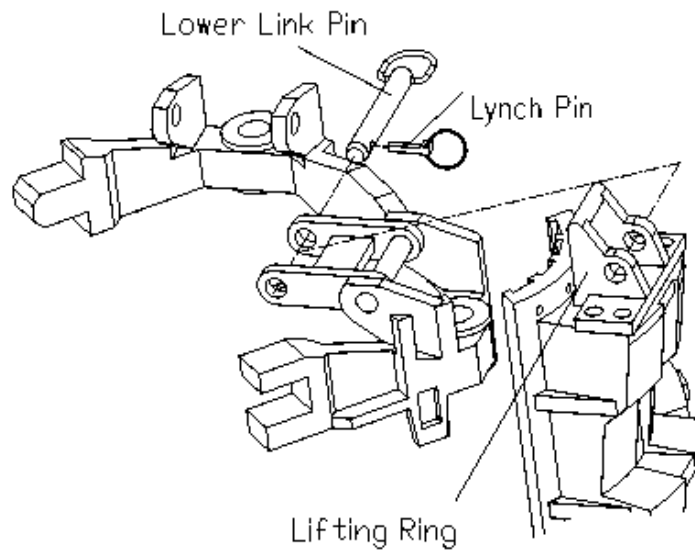

Figure 3-2

1. Removing Slip Segments-Figure 3-2

- a. Power the slip segments to the up position.
- b. Connect an overhead lift hook into slip segment lifting ring. With the weight off the remove lynch pin.
- c. Remove link pin.
- d. Remove a single slip segment.
- e. Repeat steps b through c and remove other slip segments.

2. Installing Replacement Slip Segment

- a. Apply liberal amount of multi-purpose grease to back of replacement slip segment and mating bowl surfaces.

**Note**

Back of segment and inside of Spider must be clean before applying grease and slip segments.

b. Using the hoist, lower the required slip segment in place, aligning link with mating hole on slip segment.

c. Install lower pin in place and insert lynch pin in lower pin.

d. Repeat steps a through c to install other slip segment.

#### D. Removing and Installing Guides

##### 1. Removing Guides-Figure 3-3

a. Remove removable hinge pin with lift.

b. Spread hinged body to provide access to guides.

c. Remove bolt and keeper from each side of guide ring.

d. With an overhead lift, raise the Spider body off the floor and block-up at about 4 inches.

e. Slide guide ring out of slot in bowl body.

##### 2. Installing Guides

a. Insert new guides into slot of bowl and secure in place with keeper and hex head bolt.

b. Lift and close Elevator/Spider body and replace hinge pin.

c. Operate slip segments to determine proper operation, as indicated in Section IV.

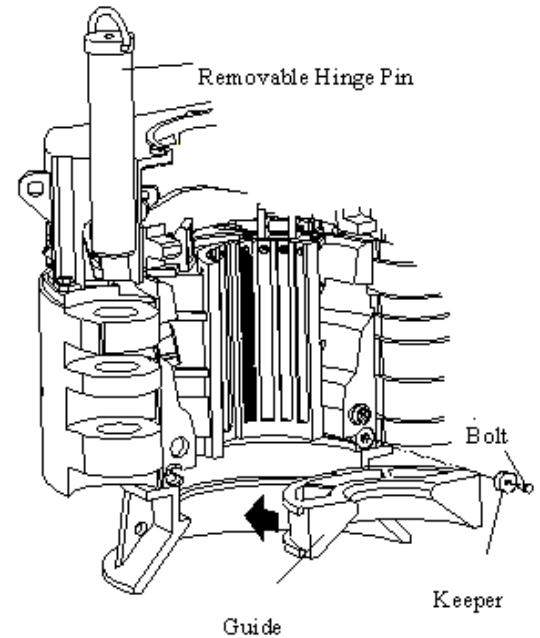

Figure 3-3

#### IV. Operation

The Elevator and Spider operation is controlled by a lever operated, control valve located on the body of each unit.

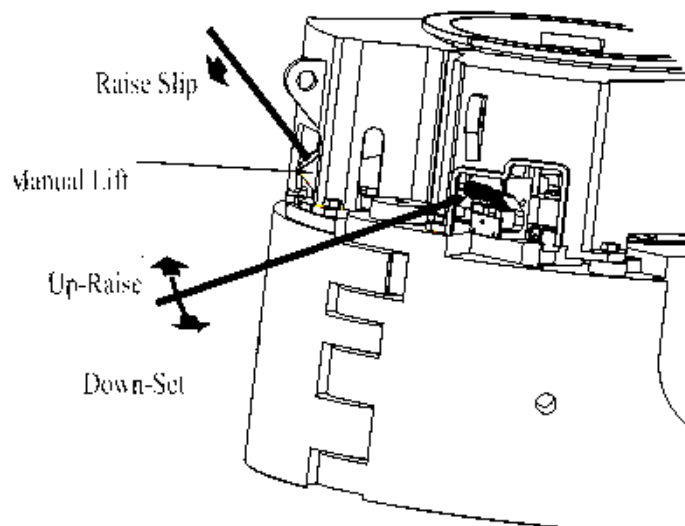

Figure 4-1



1. Moving the lever to the up position raises the slips.
2. Moving the lever to fully down position sets the slips.

If an air pressure failure should happen, the slip segments can be operated manually, as follows:

1. Place a 5 foot pry bar into manual lift lever.
2. Push down on pry bar and move the control lever handle to the up position. This moves the latch plate under the leveling beam to hold slips in the up position.
3. To set slips (lower slips) push control lever handle down.

### **Key points for operation of elevator/spider**

1. Elevator/spider must be operated after the pipe column is stably stopped; otherwise it may be seized;
2. During the release of casing, the reverse pliers must be adopted. Elevator/spider can't bear any reactive torque, otherwise it will cause the damage of equipment;
3. During the operation, adopt the anchor chain to fix the spider and make the spider center aligned to the well center;
4. During the lowering of casing, its lowering speed should be slow when the casing coupling passes inside the elevator/spider, thus it can avoid knocking at the slip body, because it may cause the damage of equipment;
5. Apply the grease (mobile oil) once every 50 casings removed; if the slip is stuck to the body, apply the flowing grease (capable of removing the impurities at the contacts of slip and body) between the slip and body immediately.

## **V、Lubrication**

Table 7

Ref. Ill	Item	Number of Lube Point	Application	Lube Cycle
1	Bowl/Slip Surfaces	16	Multi-Purpose Waterless Grease	See Note Below
2	Cylinder Assemblies	4	Multi-Purpose Waterless Grease	Before Each Job
3	Hinge Pins	2	Multi-Purpose Waterless Grease	Before Each Job
4	Flow Control Valve	2	Multi-purpose Waterless Grease	Weekly
5	Link Pins	8	SAE 10 oil	Weekly

### **Note**

Lubricate after every 50 joint casing run and more frequently if necessary to prevent slips from sticking in the Elevator or Spider Body. To lubricate properly the slips should be in the set position without any casing load on unit.  
regulator-filter

### **Maintenance**

1. Drain accumulated water as required.
2. Clean filter element with kerosene or diesel fuel every 3 months or more often if required.
3. Clean filter with clean warm water or kerosene only.

### **Caution**

The plastic bowl used on this device can be damaged and possibly fail if exposed to certain solvents, strong alkaline substances, or compressor oils containing aromatic hydrocarbons (fire retardant oils). Fumes of these substances in contact with the bowl can cause damage to the bowl.

## **VI、 Maintenance**

### **A. Preventive Maintenance**

#### **DO'S**

1. Lubricate are required in Table 4-1.
2. Check guides and gripping inserts for wear and replace as require.
3. Avoid unnecessary shock loading of slip segments.

#### **DON'TS**

1. Never paint over moving parts or grease fittings.
2. Avoid contamination of air lines.
3. Never restrict air flow.
4. Avoid dry or over-oiled lubricator.
5. Never use equipment that is not opening properly

### **B. Troubleshooting**

See Table 8

Table 8

Symptom	Possible Cause
1. Slip Segments do not operate or operate slowly in both directions	<p>a. Check air pressure at regulator is approximately 70 to 80 psig.</p> <p>b. Check if air lines are pinched or kinked leaks which could decrease air pressure.</p> <p>c. Check lubricator oil level. This unit supplies oil to lubricate the internal operation of the drive cylinder and must be kept full.</p> <p>d. Check control valve operates freely. See operation of this manual.</p> <p>e. Check if wiper on cylinders are clean. Wipers keep cylinder rods clean and will restrict cylinder action if worn.</p>
2. Pipe Slips	<p>a. Check slip size(one or two incorrect slip segments mixed with 2 or 3 correct size slip segments.)</p> <p>b. Check for incorrect, worn or resharpened inserts.</p> <p>c. Check for worn slip segments. Back size of segment is worn allowing the slip to set lower in the double step bowl and segment toe hits bottom guide, thereby preventing insert from gripping pipe.</p>
1. Damaged Pipe	<p>a. Check correct slip body size or incorrect slip segment in slip segment group.</p> <p>b. Check for incorrect, worn or resharpened inserts.</p>

**C. Transportation and Storage**

1. Crash is forbidden when in transportation of the elevator. It must be prevented from rain.
2. The products must be stored in the dry and well-ventilated place and prevented from in the sun or in the rain. It is forbidden to let the products contact acids, alkalis、 salts and some other corrosion substance.

# TYPE SE 350 TON CASING ELEVATOR/SPIDER

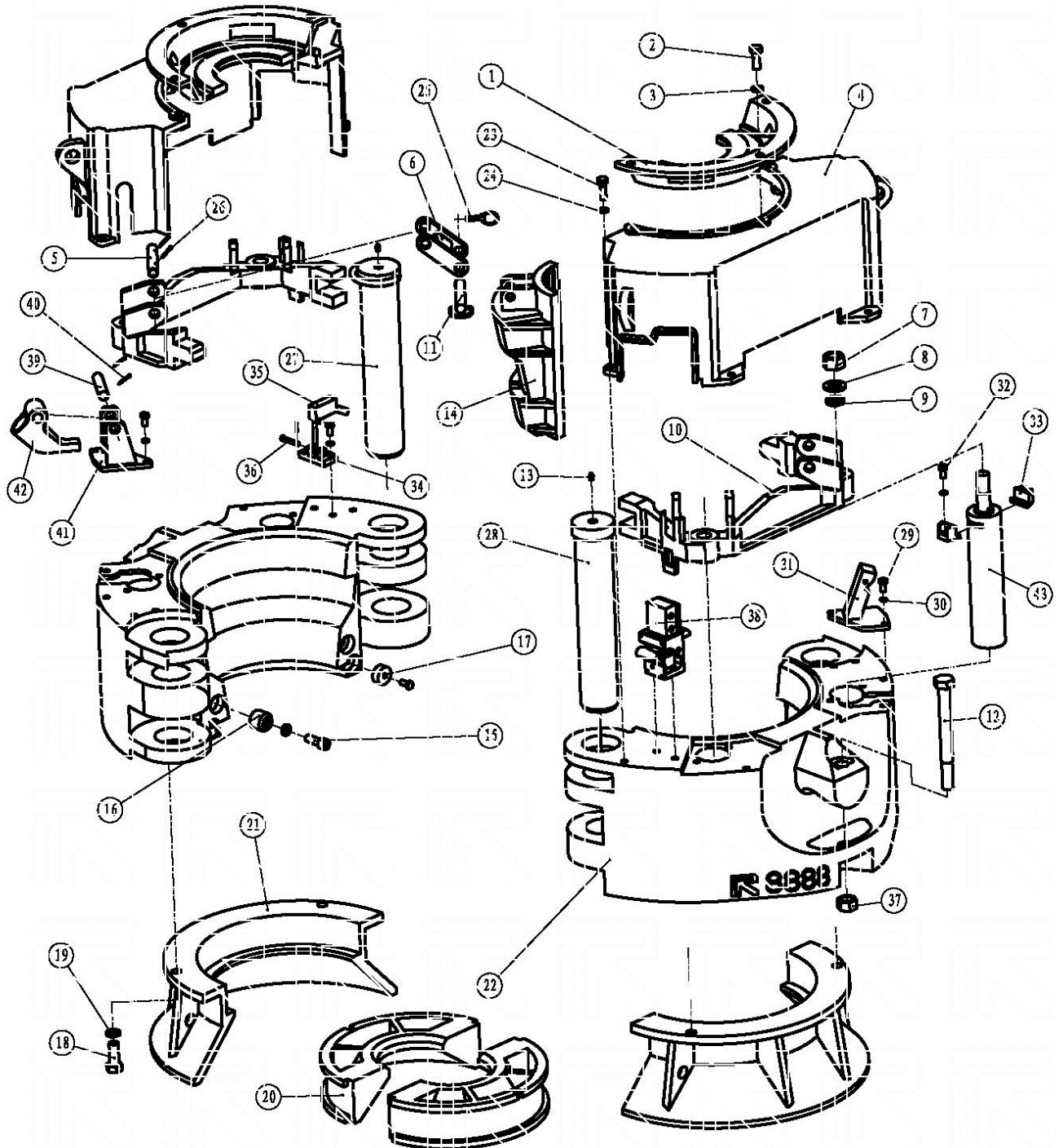

SE 4.1/2-14 350 PART LIST

No.	PART No.	DESCRIPTION	Num
	000808	TYPE SE 350 ELEVATOR/SPIDER	
1		TOP GUIDE	Each 2
2	0701548	BOLT, Hex Head	6
3	0701190	LOCKWASHER	8
4	010807010	Cover	2
5	010807008	LINK PIN, Upper	4
6	010807009	LINK, Slip Hanger	4
7		NUT, Hex,	4
8		LOCKWASHER	4
9		FLATWASHER	4
10	010807007	LEVELING BEAM	2
11	010807089	LINK PIN, Lower	4
12	010808005	SCREW, Link retainer	2
13	0305131	GREASE FITTING	10
14		SLIP SEGMENT	Each1
15	0701548	BOLT, Socket Head	2
16	010807065	BUTTON, Register	2
17	010807066	GUIDE, KEPPER	4
18	0701185	BOLT, Hex Head	4
19	0701877	LOCKWASHER	4
20		GUIDE RING	Each2
21	010807011	BELL GUIDE	2
22	010808001	BODY	2
23	0701186	BOLT, Hex Head	8
24	0701873	LOCKWASHER	8
25	010807071	LYNCH PIN	4
26	0701956	COTTER PIN	8
27		HINGE PIN, Removable	1
28	010808006	HINGE PIN, Stationary	1
29	0701180	BOLT, Hex Head	10
30	0701894	LOCKWASHER	18
31	010807074	LUBRICATOR MOUNTING BRACKET	1
32	0701181	BOLT, Hex Head	8
33	010807075	RETAINER CYLINDER	8
34	010808003	BRACKET, Latch	2
35	010808002	LATCH, Retainer	2
36	010808004	PIN	2
37		NUT	2
38	010807076	CONTROL VALVE and LATCH ASSEMBLY	4
39	010807068	PIN, PIVOT	1
40	0701938	COTTER PIN	3
41	010807069	MANUAL CONTROL BRACKET	1
42	010807070	SOCKET, MANUAL LIFT	1
43	0305069	CYLINDER	4

**350T GUIDES, SLIP ASSEMBLIES AND INSERT NUMBERS**

Casing Size (Inches)	Elevator Bottom Guide No.	Spider Top Guide No.	Slip With Inserts Set P/N	Insert Set P/N		Slip Body Size(in.)
4	010807025	010807012	010808063	001605243-24 001605244-16		5.1/2
4.1/2	010807025	010807012	010808008	001605009-24 001605010-16	2168-16B-24	5.1/2
5	010807026	010807013	010808009	001605011-24 001605012-16	2169-16B-24	5.1/2
5.1/2	010807027	010807014	010808010	001605013-40	2170-40	5.1/2
5.3/4	010807027	010807014	010808034	001605204-40-	-40	5.3/4
6.5/8	010807028	010807015	010808011	001605014-36 001605015-24	2632-24B-36	7.5/8
7	010807028	010807015	010808012	001605016-36 001605017-24	2623-24B-36	7.5/8
7.5/8	010807029	010807016	010808013	001605018-60	2633-60	7.5/8
7.3/4	010807029	010807016	010808014	001605023-60	2649-60	7.5/8
8	010807128	010807127	010808064	001605265-48 001605266-32		9.5/8
8.1/8	010807128	010807127	010808065	001605338-48 001605339-32		9.5/8
8.5/8	010807030	010807017	010808015	001605019-48 001605020-32	2640-32B-48	9.5/8
8.3/4	010807030	010807017	010808016	001605021-48 001605022-32	2650-32B-48	9.5/8
9.5/8	010807031	010807018	010808017	001605018-80	2633-80	9.5/8
9.3/4	010807032	010807019	010808018	001605023-80	2649-80	9.5/8
9.7/8	010807032	010807019	010808019	001605023-80	2649-80	9.5/8
10.3/4	010807033	010807020	010808020	001605019-60 001605020-40	2640-40B-60	11.3/4
10.7/8	010807033	010807020	010808021	001605021-60 001605022-40	2650-40B-60	11.3/4
11.3/4	010807034	010807021	010808022	001605024-100	2637-100	11.3/4
11.7/8	010807034	010807021	010808023	001605025-100	2651-100	11.3/4
12.3/4	010807130	010807129	010808066	001605340-60 001605341-40		14
13.3/8	010807035	010807022	010808024	001605026-60 001605027-40	2636-40B-60	14
13.1/2	010807036	010807023	010808025	001605028-60 001605029-40	2652-40B-60	14
13.5/8	010807036	010807023	010808026	001605030-60 001605031-40	2653-40B-60	14
13.3/4	010807036	010807023	010808027	001605032-60 001605033-40	2655-40B-60	14
14	010807037	010807024	010808011	001605034-100	2635-100	14

Note: Numbers followed by the letter “B” indicate beveled inserts

## TYPE SE 16- 20 ELEVATOR/SPIDER PART LIST

No.	PART No.	DESCRIPTION	Num
1		TOP GUIDE	Each 2
2	0701548	BOLT, Hex Head	6
3	0701190	LOCKWASHER	8
4		Cover	2
5	010807008	LINK PIN, Upper	4
6		LINK, Slip Hanger	4
7		NUT, Hex	4
8		LOCKWASHER	4
9		FLATWASHER	4
10		LEVELING BEAM	2
11	010807089	LINK PIN, Lower	4
12	010808005	SCREW, Link retainer	2
13	0305131	GREASE FITTING	2
14		SLIP SEGMENT	Each 1
15	0701548	BOLT, Socket Head	2
16	010807065	BUTTON, Register	2
17	010807066	GUIDE, KEPPER	4
18	0701185	BOLT, Hex Head	4
19	0701877	LOCKWASHER 1	4
20		GUIDE RING	Each 2
21		BELL GUIDE	2
22		BODY	2
23	0701186	BOLT, Hex Head	8
24	0701873	LOCKWASHER	8
25	010807071	LYNCH PIN	4
26	0701956	COTTER PIN	8
27		HINGE PIN, Removable	1
28	010808006	HINGE PIN, Stationary	1
29	0701180	BOLT, Hex Head	10
30	0701894	LOCKWASHER	18
31	010807074	LUBRICATOR MOUNTING BRACKET	1
32	0701181	BOLT, Hex Head	8
33	010807075	RETAINER CYLINDER	8
34	010808003	BRACKET, Latch	2
35	010808002	LATCH, Retainer	2
36	010808004	PIN	2
37		NUT	2
38	010807076	CONTROL VALVE and LATCH ASSEMBLY	4
39	010807068	PIN, PIVOT	1
40	0701938	COTTER PIN	3
41	010807069	MANUAL CONTROL BRACKET	1
42	010807070	SOCKET, MANUAL LIFT	1
43	0305069	CYLINDER	4

**SE 16-20 /350T GUIDES, SLIP ASSEMBLIES AND INSERT NUMBERS**

Casing Size (Inches)	Elevator Bottom Guide No.	Spider Top Guide No.	Slip With Inserts Set P/N	Insert Set P/N	Slip Body Size(in.)
16	010812022	010812005	010812001	001605335-120	16
18	010812023	010812006	010812004	001605334-84 001605336-28B I 001605337-28B II	18.5/8
18.5/8	010812024	010812007	010812002	001605335-140	18.5/8
20	010812025	010812008	010812003	001605335-140	20

Note: Numbers followed by the letter “B” indicate beveled inserts,

There is two type of indicate beveled inserts,  
top indicate beveled inserts and bottom indicate beveled inserts.