

**MODEL XQ114/6YB
HYDRAULIC POWER TONG**



**PARTS OPERATION AND
MAINTENANCE MANUAL**

CONTENTS

I . SUMMARY.....	1
II . SEPCIFICATION.....	1
III. INSTALLATION.....	1
IV. OPERATION.....	2
V . MAINTENANCE & LUBRICATION.....	2
VI. ORDINARY PROBLEMS AND TROUBLESHOOTING GUIDE.....	3
VII. TABLE OF JAW AND DIES.....	4
VIII. TORQUE CHART.....	4
IX. TABLE OF PARTS AND DRAWINGS.....	5
Fig.1 Shell.....	5
Fig.2 Brake mechanism and reset mechanism.....	6
Fig.3 Idle shaft.....	7
Fig.4 Hanging rod assembly.....	8
Fig.5 Power input shaft.....	9
Fig.6 Shifting mechanism assembly.....	10
Fig.7 Centralizing mechanism.....	11
Fig.8 Tong head assembly.....	12
Fig.9 Duplex gear shaft.....	13
Fig.10 Hydraulic motor.....	14
Fig.11 Safety door assembly.....	15
Fig.12 Lift assembly.....	16
Fig.13 Backup tong head.....	17
Fig.14 Backup tong tail.....	19
Fig.15 Fore guide rod assembly	21
Fig.16 Back guide rod assembly	22
Fig.17 Hand control valve.....	23

I . SUMMARY

Model XQ114/6YB(4 1/2") hydraulic power tong is an open type power tong for the making up and breaking out of tubing in well services. This product has the following features:

- 1,The tong is made up of master tong and backup tong, the master tong has a high and low gear train, the tong is compact, light and efficient.
- 2, The master tong and backup hydraulics operate on valve banks independent of each other.
- 3,The tong has incorporated a new system of disc brake to hold the jaws to connection more effectively.
- 4,Makeup and breakout are made easy with a simple turn to the reset knob on the tong and backup.
- 5,The backup has been supplied with quick coupling hoses and connections for quick and easy installation for jobs where you need a backup and the backup can be removed in seconds for jobs that a backup is not required.

II . SEPCIFICATION

- 1, Application:Tubing:73mm-114mm (2 7/8"to 4 1/2")
- 2, High gear rated torque:1.5 kN.m (1106 ft.lbs)
- 3, Low gear rated torque:6 kN.m (4425 ft.lbs)
- 4, high gear max rotation speed:85 RPM
- 5, Low gear max rotation speed:20 RPM
- 6, Opening of tong head:118 mm
- 7, Overall dimension (L×W×H):750×500×600 mm
- 8, Weight:220 kg(485lbs)
- 9, Rated system pressure:1595 Psi
- 10, Max oil supply:100 L/ min

III. INSTALLATION

A, Hanging: Connect lift with tong hanging rod and hang the tong on the derrick of workover rig, the hanging point is 15 m above ground and the hanging should be in free condition. The distance between the tong center and the center of the well is recommended to be 0.5m. The hanging height is proper when the backup tong could rightly grip the tubing collar.

B, Level: Adjust the screw (Z6-58)on the tong hanger to level the tong and backup, this should be done to ensure proper gripping of the jaws.

C, Back guy: Tie one end of back guy on derrick and the other end on back guide seat of power tong, back guy should be capable of bearing a load of 20 KN, when power tong is in make up position, the back guy should be at right angle to the tong and on the opposite side of operator who operates the control handles, this insures a safe operation.

D, Pressure hoses: Connect hoses from the hydraulic power source to the control valve bank of the power tong. The inlet and the outlet hoses can't be misconnected.

IV. OPERATION

Making up tubing can be spun first in high gear range, final torques must be done in the low gear range. A PSI chart is provided to convert PSI to FT.LBS torque.

Break out must be started in low gear range, once the joint has been loosened, the final brake out can be done in the high gear range.

1, Make-up:

After aligning the opening tong head with the backup, turn the reset knobs of each (Z6-49) and (B6-3) switch the arrow to point the direction of make-up. Locate the tong and backup on to the tubing. The backup should be engaged to lock onto the tubing first.

Once the backup jaws have been locked on, commence make up with the tong. After the tubing is made up, reserve rotation of the tong to align the opening of the tong with the tubing. Once this is accomplished, reverse the backup to align the opening of the backup to the tubing. The tong can be moved off the tubing. Confirm proper make up torques required from your tubing supplier.

2. Break out

Aligning the opening tong head with the backup, turn the reset knobs of each(Z6-49) and (B6-3) and switch them to point the direction of break out, then push it towards the tubing. Making the jaws of the tong and the backup line up squarely on tubing. Engage the backup first locking onto the tubing. Commence break out with the tong. Initial break out should always be done in low gear range. Once break out is accomplished. The joint may be spun off in high gear. To come off the couplings reverse the rotation of the tong and backup slowly to align the opening of the tong and backup to the tubing. The tong can now be removed off the tubing.

3. Replacing jaws.

Tong and backup insert jaws slide into the tong heads easily. When you dismount jaws, turn tong head firstly, make the stop screw on the jaw set bracket expose from the opening tong head, loose the stop screw, then you can take out the jaws from the center of tong head. Mounting operation procedure is just on the contrary .

V. MAINTENANCE & LUBRICATION

It is suggested that a regular maintenance program be established, to assure dependable operation of the tubing tong. The following recommendations concerning cleaning, lubrication, and cleaning will enhance the life expectancy of the tong and assure safety to operating personnel.

A, Cleaning

The tong should be thoroughly cleaned with a good petroleum base cleaning agent, after each job, prior to storage, it is recommended that periodically the motor and valve assembly be removed, along with the top tong plate, so that guides, rollers and gears can be properly cleaned.

B, lubrication

A good grade of multipurpose bearing lubricant which is compatible with expected ambient temperature is recommended along with the following lubrication procedures, at the completion of each job prior to storage.

1, All grease fittings should have 2 to 5 shots of grease after each job.

2, Rotary gear cam surface should be well greased applying with a rag or a brush.

3, Cage plates/rings should be coated with grease both through the grease nipples and coated on the rings.

4, Gears can be greased by removed the side inspection cover plate and apply grease directly to the gear teeth.

VI. ORDINARY PROBLEMS AND TROUBLESHOOTING GUIDE

TROUBLE	CAUSE.	REMEDY
TONG DIE SLIPPAGE	A, JAWS ARE SELECTED IMPROPERLY.	CHANGE JAWS TO PROPER SIZE.
	B, GRIT/MUD ETC.FILL DIE GROOVES.	CLEAN THE DIES.
	C, TONG DIES WORN.	CHANGE TO NEW DIES.
	D, DISC BRAKE LOOSE.	TIGHTEN DISC BRAKE SPRINGS.
	E, TONG IS NOT LEVEL.	ADJUST LEVELING SCREW ON RIGID SLING.
CAGE PLATES ON TONG OR BACKUP WILL NO ALIGHT WITH OPENING BODY	RETAINING PINS (Z-69) (B6-5) ARE NOT WRAPPED BY RESET KNOB SHAFT	TURN RESET KNOBS(Z6-49) and (B6-3) 180° THEN RESET.
BACKUP TONG SLIPPAGE	HYDRAULIC PRESSURE DROP/ OR HYDRAULIC LEAKS.	CHECK VALVE PRESSURE IN INCREASE SYSTEM PRESSURE/ REPLACE VALVE SEALS IF REQUIRED.
ENGAGING A GEAR IS NOT FIRM AND IT DISENGAGE EASILY	LOCKING EFFORT IS A LITTLE SMALL.	ADD ADJUSTING SHIM AND INCREASE THE PRESSURE OF SPRING.

VII. TABLE OF JAW AND DIES

The table of jaw specification

Tubing size	Tong-jaw size		Backup-jaw size		
	Purchasing number	Mark	Purchasing number	Mark	Remark
2-3/8"	Z6-79(1)	60-56	B6-31(1)	63-60	grip main body
			B6-31(2)	73-70	grip collar
			B6-31(3)	78-75	grip (EU) collar
2-7/8"	Z6-79(2)	73-69	B6-31(4)	93-89	grip collar
			B6-31(2)	73-70	grip main body
3-1/2"	Z6-79(3)	89-85	B6-31(5)	114.5-107	grip collar
			B6-31(4)	93-89	grip main body
4"	Z6-79(4)	105	B6-31(5)	114.5-107	grip small drill pipe
4-1/2"	Z6-79(5)	114-110	B6-31(5)	114.5-107	grip main body
			B6-31(6)	141.5-132.5	grip collar

Remark: The customer could select to purchase above jaws according to the requirement.

Dies specification

Tubing size	Dies for tong and backup	
	Purchasing number	Mark
2-3/8" — 2-7/8"	Z6-73(1)	60-78
3-1/2" — 4-1/2"	Z6-73(2)	89-142

VIII. TORQUE CHART

PSI VS FT.LBS. (4-1/2 TONG)

PSI	LOW	HIGH
100	312	78
200	625	156
300	936	234
400	1249	313
500	1562	391
600	1874	469
700	2186	547
800	2499	625
900	2810	703
1000	3123	781
1100	3435	859
1200	3748	938
1300	4060	1016
1400	4372	1094
1500	4685	1172
1600	4997	1250

IX. TABLE OF PARTS AND DRAWINGS

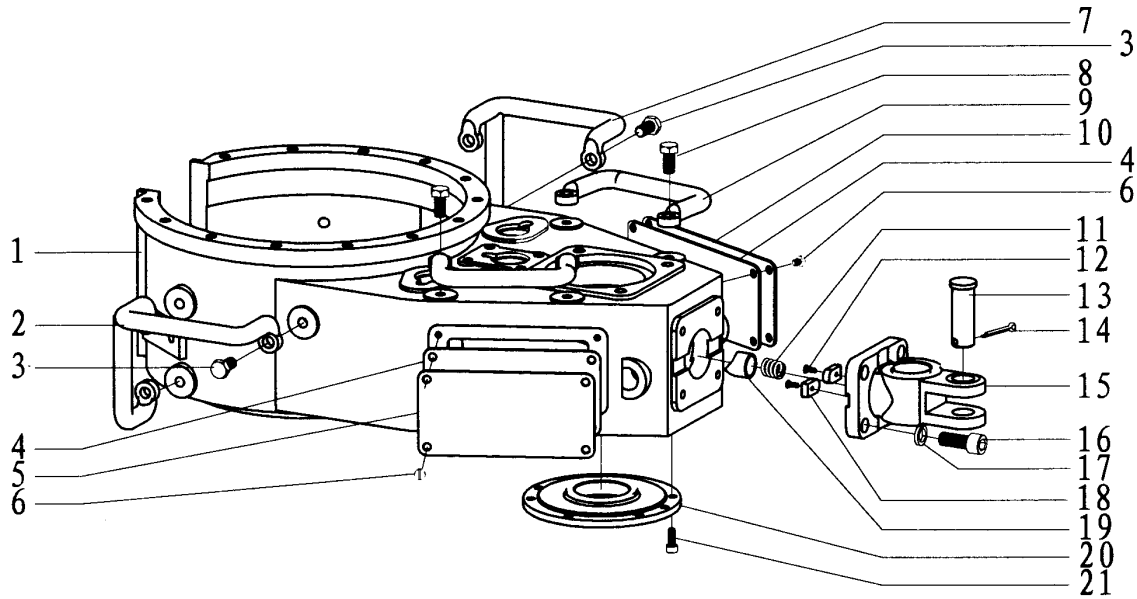
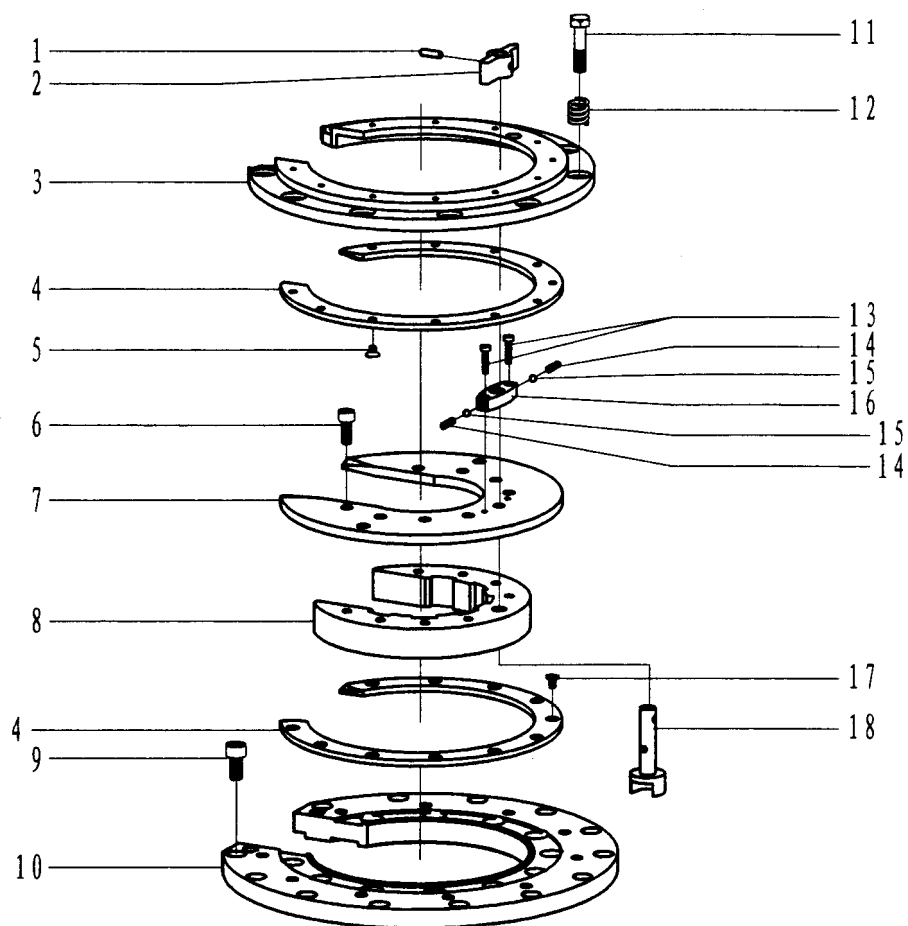

Fig. 1 Shell

Item	Purchasing number	Part number	Part name	QTY
1	Z6-4	XYQ6B.Z-2	Shell	1
2	Z6-57	XYQ6B.Z.3	Fore handle assembly (LH)	1
3	Z6-3	GB5782-86	Hex bolt M10×20-8.8	6
4	Z6-62	XYQ6B.Z-31	Retainer plate	2
5	Z6-130	XYQ3B.Z-69	Pressure and torque relationship table	1
6	Z6-126	GB65-85	Slotted cylinder head screw M6 × 10-4.8	12
7	Z6-67	XYQ6B.Z.4	Fore handle assembly (RH)	1
8	Z6-1	GB70-85	Hexagon socket head cap screw M10×20-8.8	4
9	Z6-61	XYQ3B.Z-34	Back handle	2
10	Z6-129	XYQ6B.Z-68	Name plate	1
11	Z6-28	XYQ3B.Z-6	Brake spring	1
12	Z6-56	GB68-85	Slotted countersunk screw M5 × 15-4.8	2
13	Z6-27	XYQ6B.Z-15	Tail guy pin	1
14	Z6-26	GB91-86	Cotter 4 × 30	1
15	Z6-32	XYQ6B.Z-18	Back guide rod seat	1
16	Z6-30	GB70-85	Hexagon socket head cap screw M12 × 30-8.8	4
17	Z6-31	GB93-87	Spring washer 12	4
18	Z6-55	XYQ6B.Z-29	Parallel key	2
19	Z6-29	XYQ6B.Z-17	Slide	1
20	Z6-23	XYQ6B.Z-13	Bottom cover	1
21	Z6-25	GB70-85	Hexagon socket head cap screw M8 × 20-8.8	6



Item	Purchasing number	Part number	Part name	QTY
1	Z6-50	GB119-86	Cylinder pin 5 × 18	1
2	Z6-49	XYQ3B.Z.1-7	Reset knob	1
3	Z6-44	XYQ6B.Z-23	Brake disc	1
4	Z6-46	XYQ6B.Z-24	Friction disc	2
5	Z6-45	GB68-85	Slotted countersunk screw M5 × 8-4.8	13
6	Z6-25	GB70-85	Hexagon socket head cap screw M8 × 20-8.8	8
7	Z6-48	XYQ6B.Z-26	Brake steel plate	1
8	Z6-47	XYQ6B.Z-25	Connecting plate	1
9	Z6-66	GB70-85	Hexagon socket head cap screw M10 × 25-8.8	15
10	Z6-43	XYQ6B.Z-22	Tong cover	1
11	Z6-54	GB32.2-88	Hex bolt M10 × 35-8.8	12
12	Z6-28	XYQ3B.Z-6	Brake spring	12
13	Z6-53	GB65-85	Slotted cylinder head screw M5 × 20-5.8	2
14	Z6-52	XYQ3B.B-20	Spring	2
15	Z6-117	GB308-89	Steel ball 5	2
16	Z6-128	XYQ3B.Z.1-20	Locating seat	1
17	Z6-21	GB68-85	Slotted countersunk screw M5 × 10-4.8	13
18	Z6-51	XYQ6B.Z-27	Reset knob shaft	1

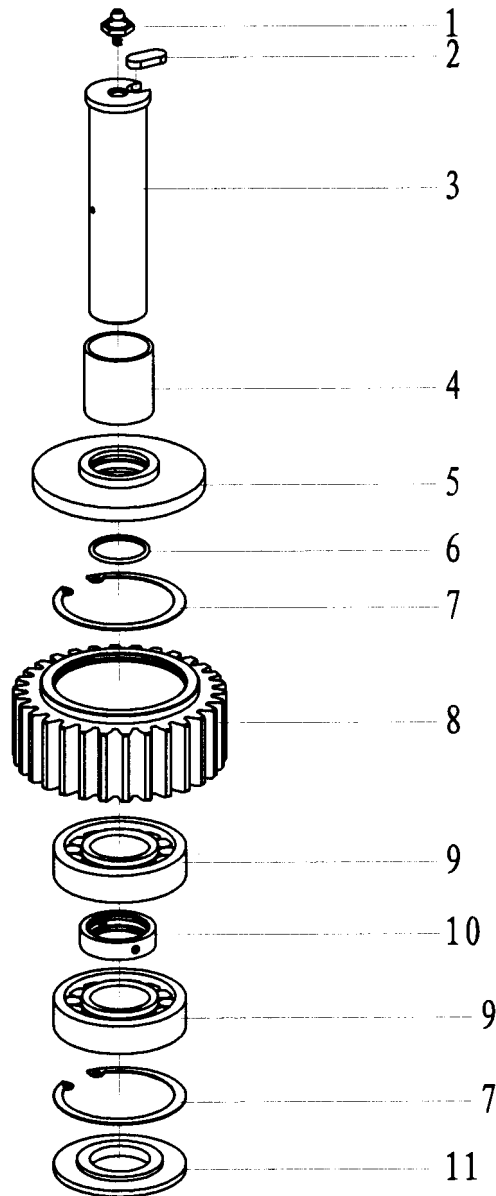

Fig. 3 Idle shaft

Item	Purchasing number	Part number	Part name	QTY
1	Z6-39	GB1152-89	Oil cup M8 × 1	2
2	Z6-38	XYQ6B.Z-67	Locating plate	2
3	Z6-97	XYQ6B.Z-48	Idle gear shaft	2
4	Z6-98	XYQ6B.Z-49	Sleeve	2
5	Z6-100	XYQ6B.Z-50	Waterproof guard	2
6	Z6-99	GB1235-76	O ring 36 × 3.5	2
7	Z6-102	GB893.1-86	Circlip 72	4
8	Z6-105	XYQ6B.Z-53	Idle gear	2
9	Z6-103	GB283-87	Short roller bearing 42306	4
10	Z6-101	XYQ6B.Z-51	Space ring	2
11	Z6-104	XYQ6B.Z-52	Washer plate	2

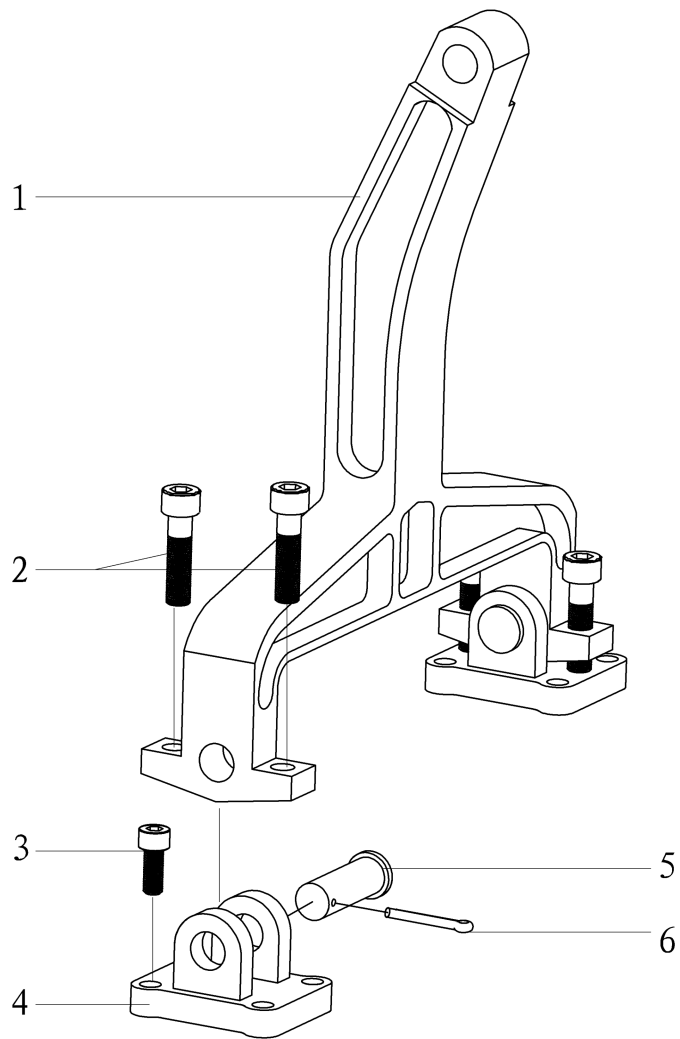

Fig. 4 Hanging rod assembly

Item	Purchasing number	Part number	Part name	QTY
1	Z6-42	XYQ6X.1-29	Hanging rod	1
2	Z6-58	GB70-85	Hexagon socket head cap screw M10 × 35-8.8	4
3	Z6-25	GB70-85	Hexagon socket head cap screw M8 × 20-8.8	8
4	Z6-59	XYQ6X.1-28	Hanging rod seat	2
5	Z6-40	XYQ3B.Z-36	Hanging pin shaft	2
6	Z6-41	GB91-86	Cotter 4×25	2

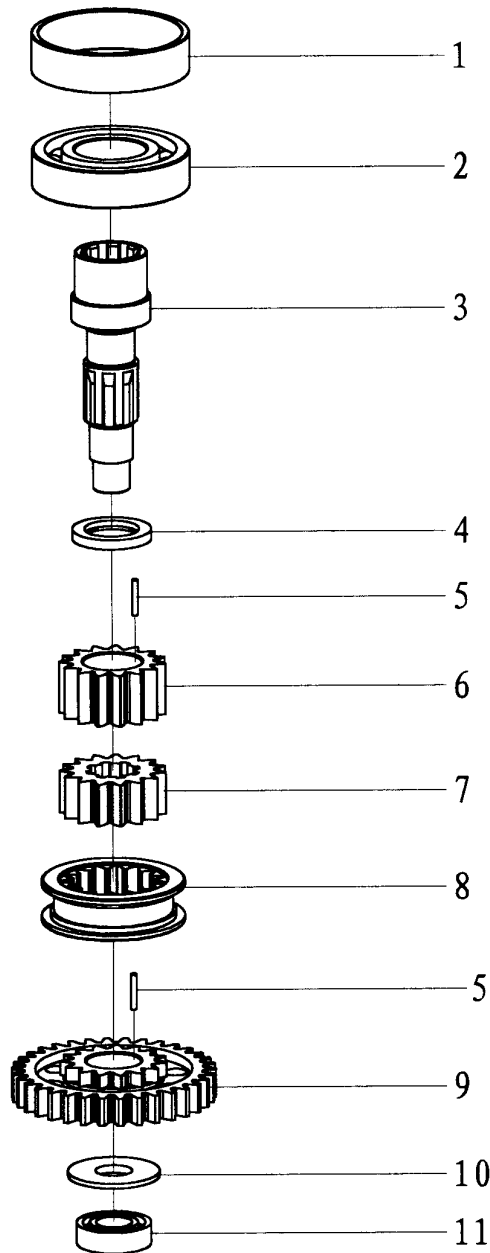

FIG.5 Power input shaft

Item	Purchasing number	Part number	Part name	QTY
1	Z6-114	XYQ6B.Z-57	Motor liner ring	1
2	Z6-115	GB276-94	Deep groove ball bearing 310	1
3	Z6-111	XYQ6B.Z-55	Power input shaft	1
4	Z6-36	XYQ6B.Z-19	Centralizing washer	2
5	Z6-17	GB309-84	Roller needle $\Phi 4 \times 25.8$	55
6	Z6-16	XYQ6B.Z-8	Shifting gear	1
7	Z6-19	XYQ6B.Z-10	Spline gear	1
8	Z6-18	XYQ6B.Z-9	Inner gear sleeve	1
9	Z6-20	XYQ6B.Z.1	Clutch gear assembly	1
10	Z6-24	XYQ6B.Z-14	Bearing disc	1
11	Z6-22	GB276-94	Deep groove ball bearing 6305	1

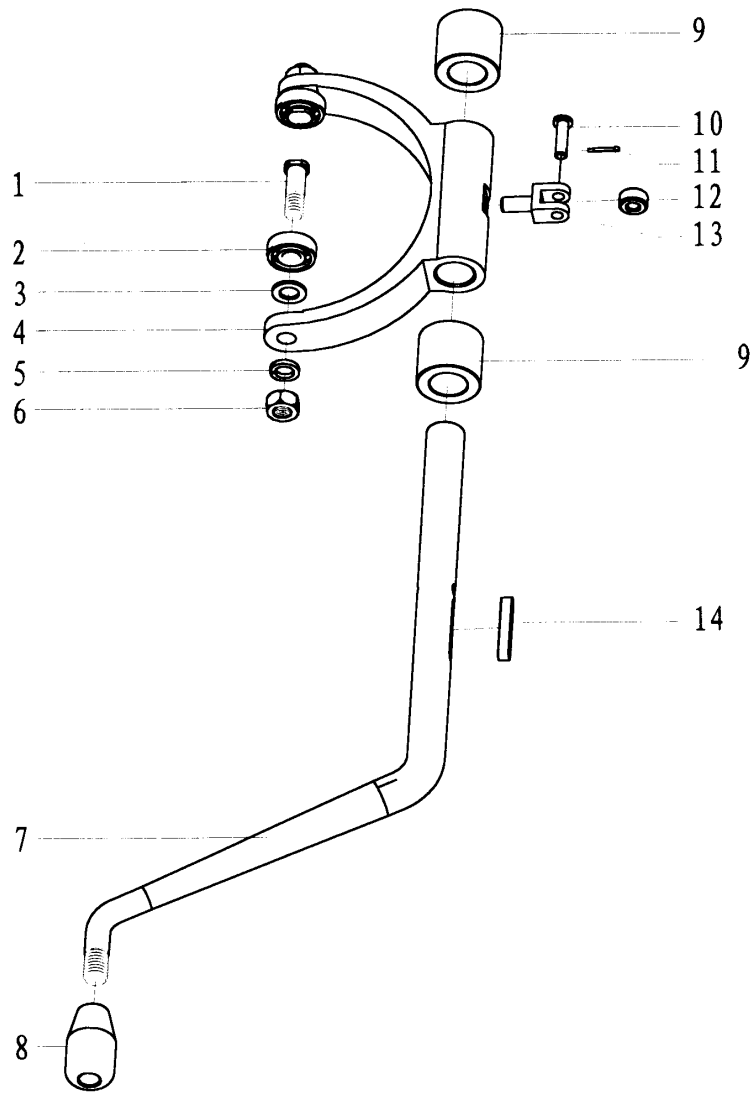

Fig.6 Shifting mechanism assembly

Item	Purchasing number	Part number	Part name	QTY
1	Z6-93	XYQ6B.Z-47	Small shaft	2
2	Z6-91	XYQ6B.Z-44	Roller sleeve	2
3	Z6-92	GB848-85	Small washer 8-140HV	2
4	Z6-84	XYQ6B.Z-45	Fork	1
5	Z6-94	GB93-87	Spring washer 8	2
6	Z6-95	GB6172-86	Hex thin nut M8-05	2
7	Z6-90	XYQ6B.Z-46	Fork shaft	1
8	Z6-96	XYQ3B.Z.5-10	Handle	1
9	Z6-83	XYQ3B.Z.6-1	Shaft sleeve	2
10	Z6-86	XYQ3B.Z.6-4	Roller shaft	1
11	Z6-87	GB91-86	Cotter 2 × 10	1
12	Z6-85	XYQ3B.Z.6-3	Roller	1
13	Z6-88	XYQ3B.Z.6-5	Roller seat	1
14	Z6-89	XYQ3B.Z.6-6	Parallel key	1

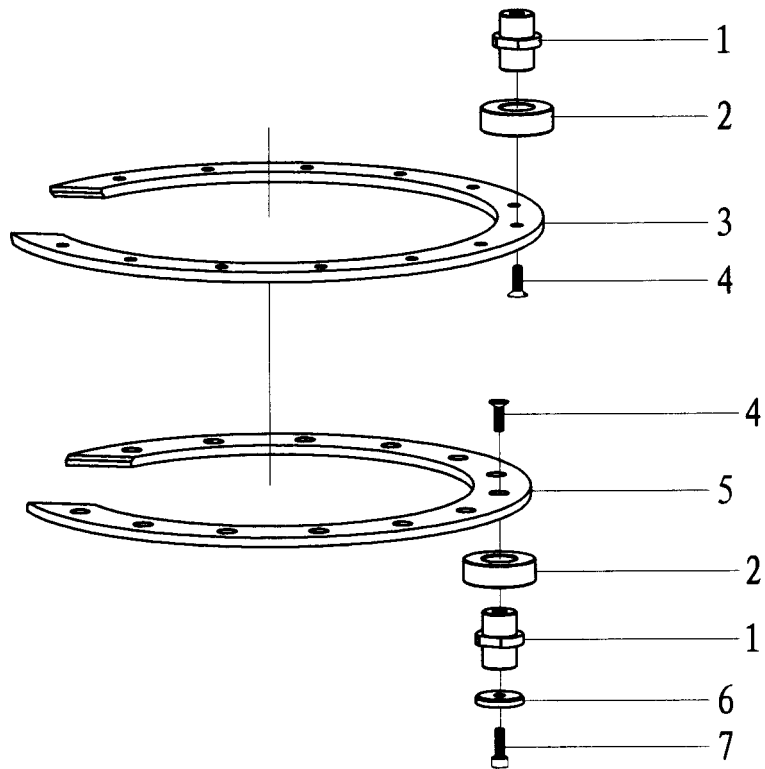

Fig. 7 Centralizing mechanism

Item	Purchasing number	Part number	Part name	QTY
1	Z6-7	XYQ6B.Z-4	Centralizing roller shaft	26
2	Z6-5	XYQ3B.Z-1	Centralizing roller	26
3	Z6-46	XYQ6B.Z-24	Friction disc	1
4	Z6-45	GB68-85	Slotted countersunk screw M5 × 10-4.8	26
5	Z6-6	XYQ6B.Z-3	Bottom bearing disc	1
6	Z6-9	GB891-86	Retainer ring B18	13
7	Z6-8	GB70-85	Hexagon socket head cap screw M5×15-8.8	13

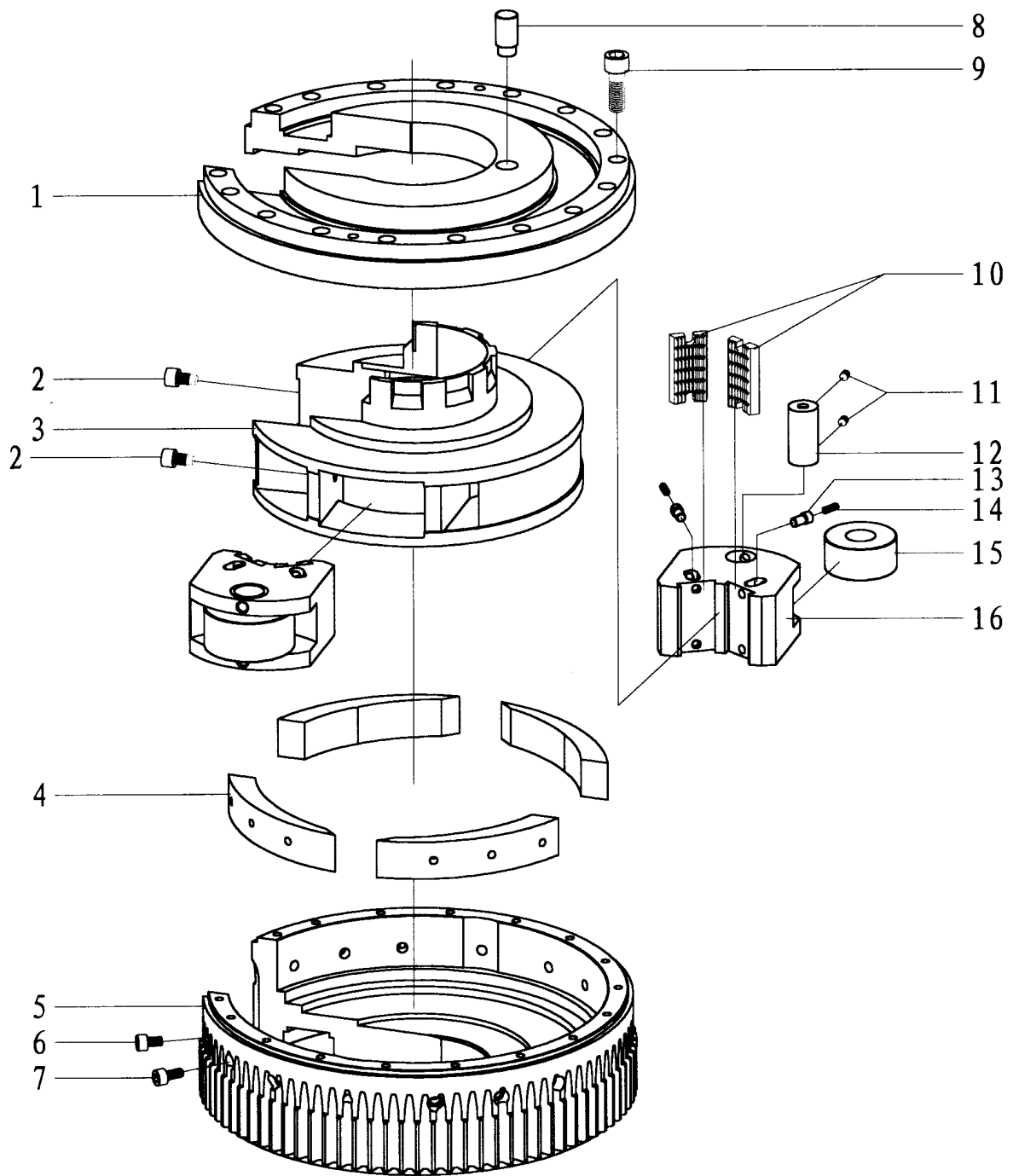

Fig. 8 Tong head assembly

Item	Purchasing number	Part number	Part name	QTY
1	Z6-70	XYQ6B.Z-34	Open gear cover	1
2	Z6-81	XYQ6B.Z-32	Stop screw M12 × 25	2
3	Z6-71	XYQ6B.Z-35	Jaw set bracket	1
4	Z6-80	XYQ6B.Z-43	Ramp	4
5	Z6-72	XYQ6B.Z-36	Open gear	1
6	Z6-1	GB70-85	Hexagon socket head cap screw M10×20-8.8	4

7	Z6-82	GB70-85	Hexagon socket head cap screw M10×16-8.8	4
8	Z6-69	XYQ6B.Z-33	Retainer pin 14 × 40	1
9	Z6-68	GB70-76	Hexagon socket head cap screw M8 × 30	13
10	Z6-73	XYQ6B.Z-37	Die piece	4
11	Z6-77	GB71-85	Slotted cone end fastening screw M10 × 10-14H	4
12	Z6-76	XYQ6B.Z-40	Roller shaft	2
13	Z6-74	XYQ6B.Z-38	Die piece retainer pin	8
14	Z6-75	XYQ3B.Z.1-18	Spring	8
15	Z6-78	XYQ6B.Z-41	Roller	2
16	Z6-79	XYQ6B.Z-42	Jaw set	2

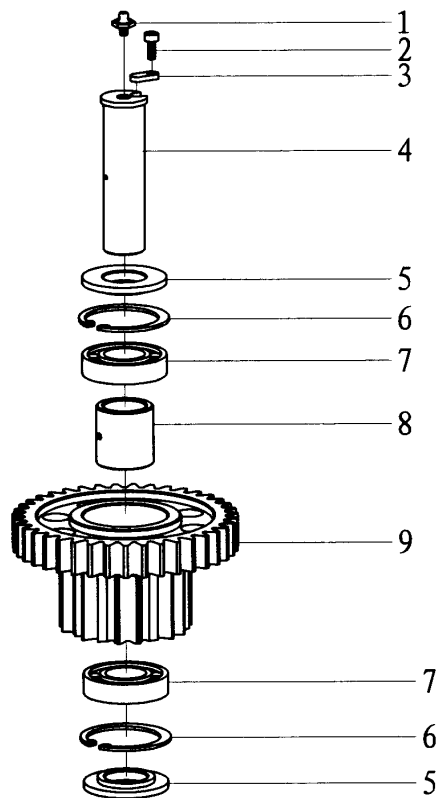

Fig. 9 Duplex gear shaft

Item	Purchasing number	Part number	Part name	QTY
1	Z6-39	GB1152-89	Oil cup M8 × 1	1
2	Z6-37	GB70-85	Hexagon socket head cap screw M6 × 15-8.8	1
3	Z6-38	XYQ6B.Z-20	Locating plate	1
4	Z6-14	XYQ6B.Z-6	Duplex gear shaft	1
5	Z6-13	XYQ6B.Z-12	Support ring	2
6	Z6-12	GB893.1-86	Circlip 62	2
7	Z6-11	GB271-87	Bearing 42206	2
8	Z6-15	XYQ6B.Z-7	Space ring	1
9	Z6-10	XYQ6B.Z-5	Duplex gear	1

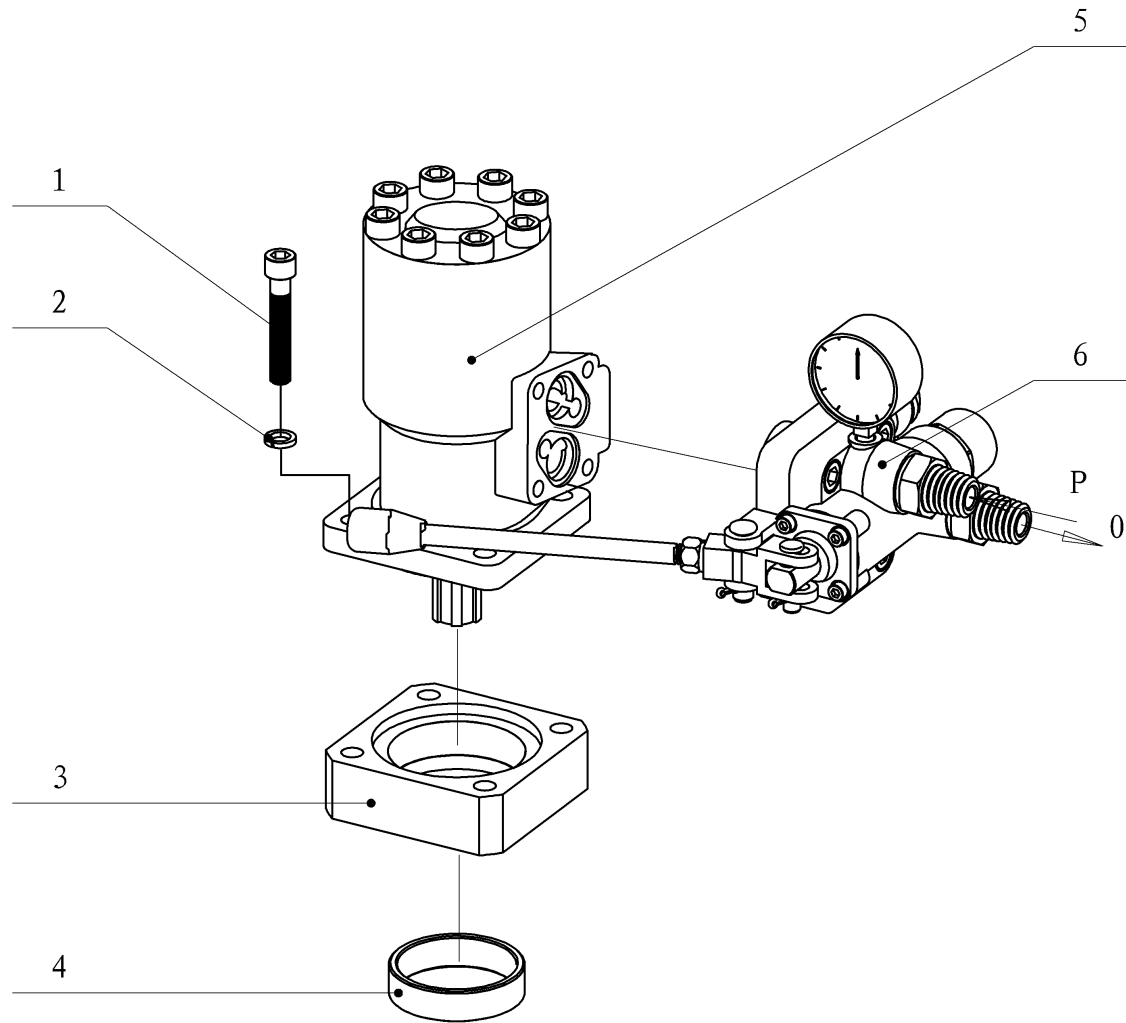

Fig. 10 Hydraulic motor

Item	Purchasing number	Part number	Part name	QTY
1	Z6-113	GB70-85	Hexagon socket head cap screw M12 × 40-8.8	4
2	Z6-31	GB93-87	Spring washer 12	4
3	Z6-112	XYQ6B.Z-56	Motor connecting seat	1
4	Z6-114	XYQ6B.Z-57	Motor sleeve	1
5	Z6-35		Hydraulic motor BM-D500	1
6	Z6-131	XYQ3C.Z.5	Hand control valve	1

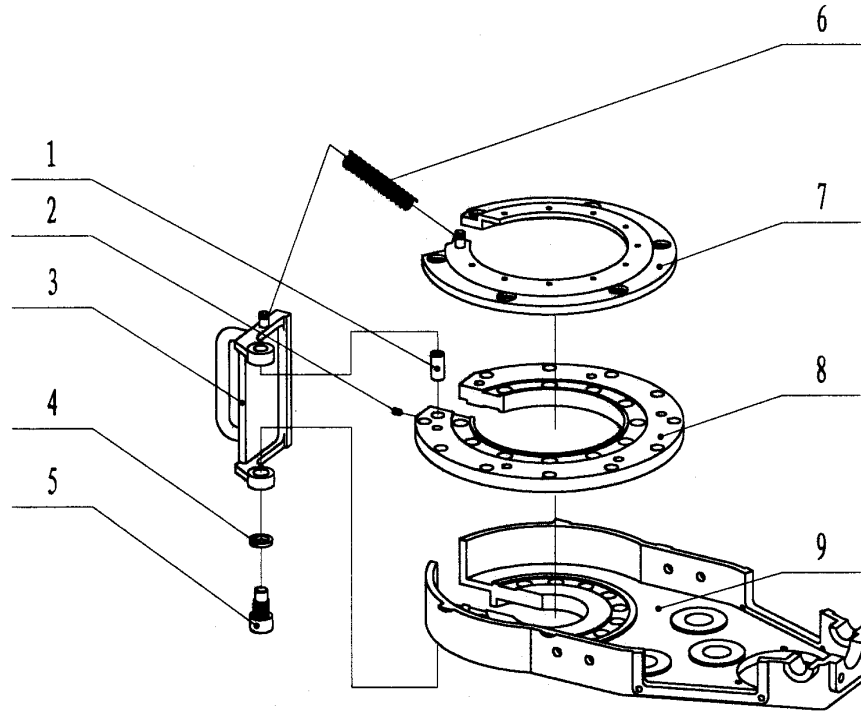

Fig. 11 Safety door assembly

Item	Purchasing number	Part number	Part name	QTY
1	Z6-119	XYQ6B.Z-62	Rotation shaft (1)	1
2	Z6-122	GB71-85	Slotted cone end fastening screw M6×16	1
3	Z6-120	XYQ6B.Z.5	Safety door	1
4	Z6-132	GB93-87	Spring washer 16	1
5	Z6-124	XYQ6B.Z-66(2)	Rotation shaft	1
6	Z6-124	XYQ6B.Z-65	Pull spring	1
7	Z6-44	XYQ6B.Z-23	Brake disc	1
8	Z6-43	XYQ6B.Z-22	Tong cover	1
9	Z6-4	XYQ6B.Z-2	Shell	1

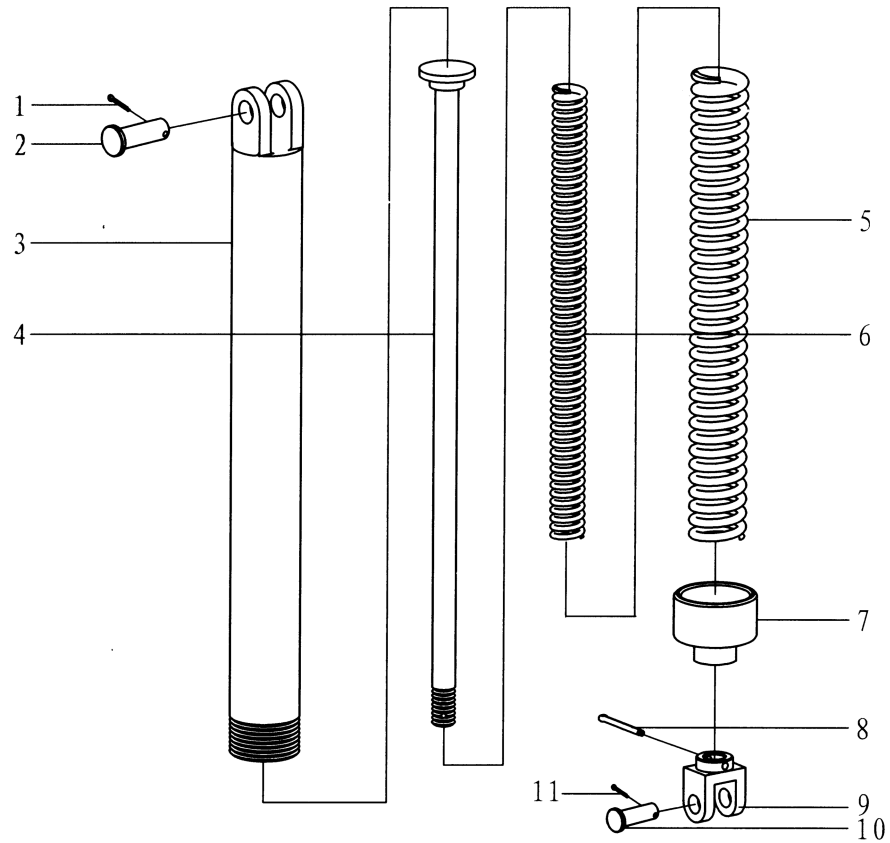

Fig. 12 Lift assembly

Item	Purchasing number	Part number	Part name	QTY
1	DT6-10	GB91-86	Cotter 4×30	1
2	DT6-9	GB882-86	Pin shaft B20×60	1
3	DT6-7	XYQ3C.DT.2	Lift main body assembly	1
4	DT6-5	XYQ3C.DT.1	Lift rod assembly	1
5	DT6-6	XYQ6B.DT-1	Lift big spring	1
6	DT6-8	XYQ3C.DT-3	Subsidiary spring	1
7	DT6-4	XYQ3C.DT-2	Lift end cover	1
8	DT6-11	GB91-86	Cotter 5×50	1
9	DT6-2	GB6172-86	Hex thin nut M16-04	1
10	DT6-3	GB882-86	Pin shaft B16×55	1
11	DT6-1	GB91-86	Cotter 3.2×26	1

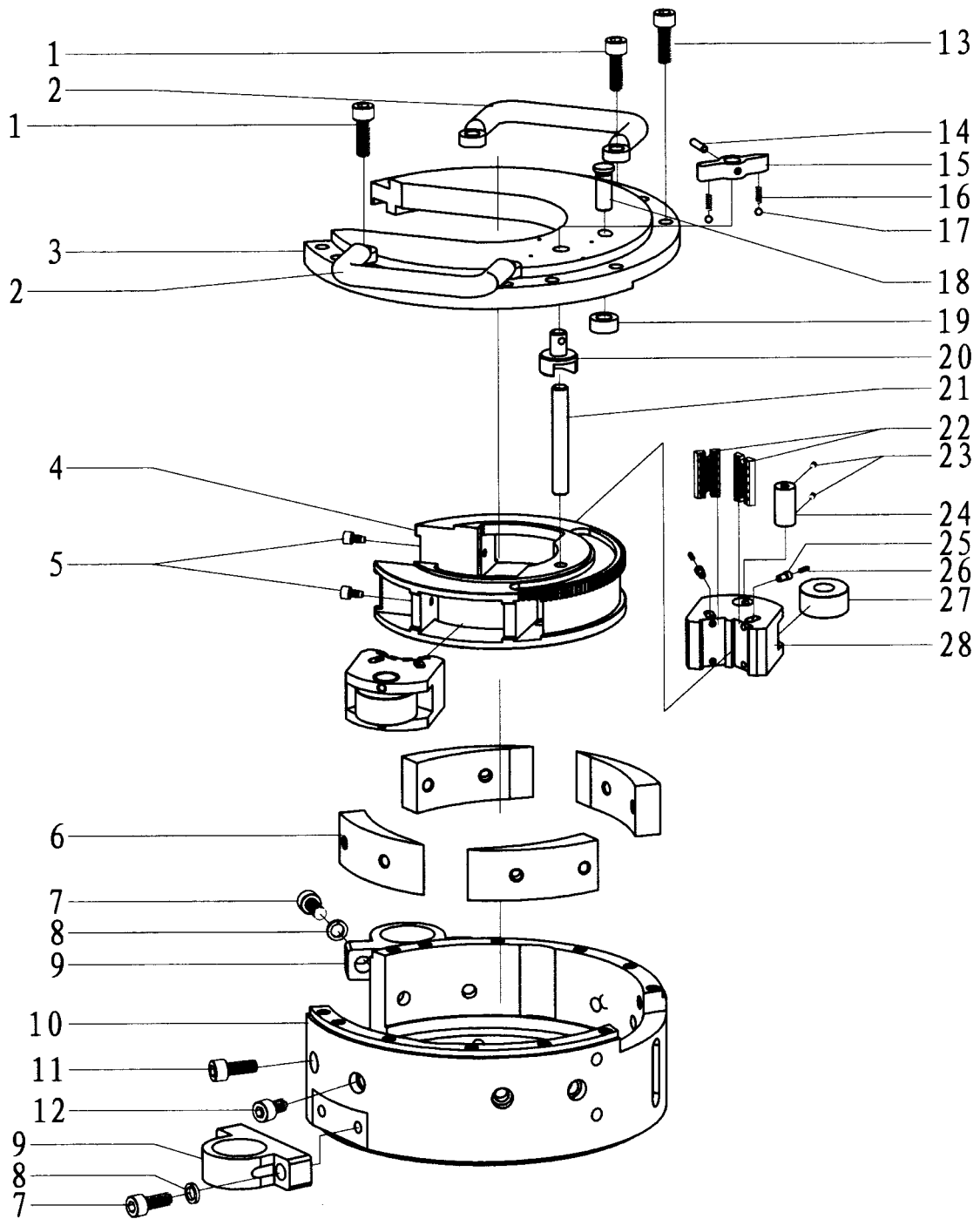

Fig. 13 Backup tong head

Item	Purchasing number	Part number	Part name	QTY
1	3C1-70	GB70-85	Hexagon socket head cap screw M8×25-8.8	4
2	B6-64	XYQ1.8Z-24	Tong head handle	2
3	B6-1	XYQ6B.B-1	Backup tong head cover	1
4	B6-6	XYQ6B.B-5	Backup tong jaw set bracket	1
5	B6-25	XYQ6B.Z-44	Set screw	2
6	B6-24	XYQ6B.B-13	Ramp	4
7	B6-22	GB70-85	Hexagon socket head cap screw M12×25-8.8	4
8	B6-23	GB93-87	Spring washer 12	4
9	B6-21	XYQ6B.B-12	Backup fore support seat	2
10	B6-7	XYQ6B.B-6	Backup tong head main body	1
11	B6-20	GB70-85	Hexagon socket head cap screw M12×20-8.8	4
12	B6-67	GB70-85	Hexagon socket head cap screw M12×15-8.8	4
13	B6-63	GB70-85	Hexagon socket head cap screw M10×30-8.8	12
14	B6-2	GB119-86	Cylinder pin 5×18	1
15	B6-3	XYQ3B.B-2	Backup reset knob	1
16	B6-16	XYQ3B.B-20	Spring	2
17	B6-17	GB308-89	Steel ball 5	2
18	B6-65	XYQ6B.B-25	Centralizing shaft	1
19	B6-66	XYQ6B.B-26	Centralizing roller	1
20	B6-4	XYQ6B.B-3	Backup reset knob shaft	1
21	B6-5	XYQ6B.B-4	Retainer pin	1
22	B6-32	XYQ6B.Z-37	Die	2
23	B6-28	GB71-85	Slotted cone end fastening screw M6×10-14H	4
24	B6-30	XYQ6B.Z-40	Roller shaft	2
25	B6-27	XYQ6B.Z-38	Die retainer pin	8
26	B6-26	XYQ3B.Z.1-18	Spring	8
27	B6-29	XYQ6B.Z-41	Roller	2
28	B6-31	XYQ6B.B-14 (1) - (5)	Jaw set	2 pcs for each kind

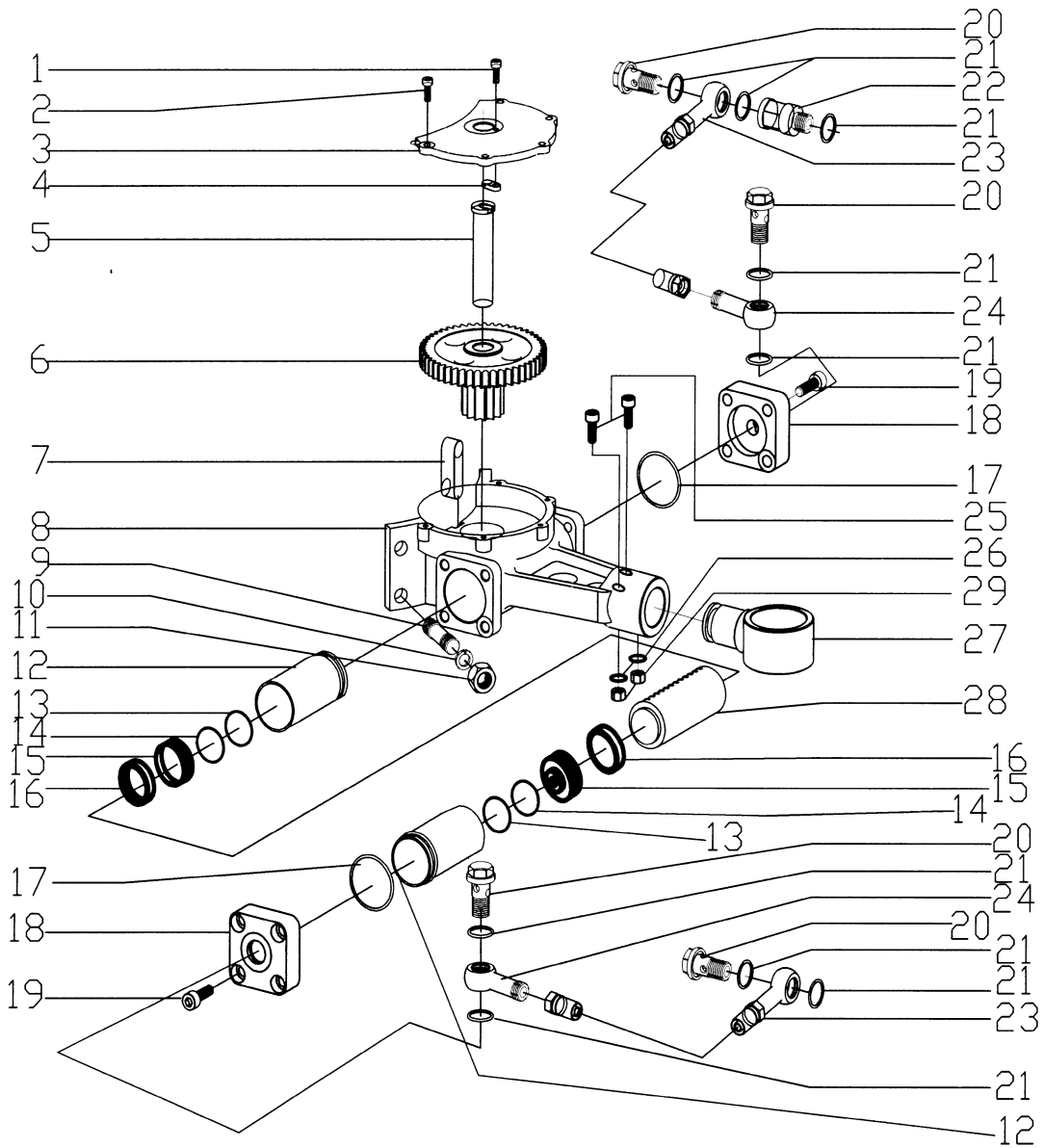

Fig. 14 Backup tong tail

Item	Purchasing number	Part number	Part name	QTY
1	B6-10	GB70-85	Hexagon socket head cap screw M6 × 15-8.8	3
2	B6-13	GB70-85	Hexagon socket head cap screw M6 × 20-8.8	5
3	B6-12	XYQ6B.B-9	Gear cover	1
4	B6-9	XYQ6B.Z-20	Setting plate	1
5	B6-8	XYQ6B.B-7	Rotation shaft	1
6	B6-11	XYQ6B.B-8	Duplex gear	1
7	B6-68	GB1096-76	Parallel key 16 × 10 × 56	2
8	B6-15	XYQ6B.B-10	Tong tail oil cylinder	1
9	B6-34	GB898-88	Double head bolt M16 × 55-8.8	4
10	B6-33	GB93-87	Spring washer 16	4
11	B6-47	GB6170-86	Hex head nut M16-8	4
12	B6-37	XYQ6B.B-15C	Cylinder cover	2
13	B6-71	GB1235-76	O ring 40 × 3.1	2
14	B6-72	GB1235-76	RingA40 × 1.5	2
15	B6-73	XYQ6B.B-22A	Plunger	2
16	B6-74	XYQ6B.B-27	Support ring	2
17	B6-75	GB1235-76	O ring 55 × 3.1	2
18	B6-38	XYQ6B.B-16B	Oil cylinder cover	2
19	B6-35	GB70-85	Hexagon socket head cap screw M10 × 30-8.8	8
20	B6-13	XYQ3B.B-9	Oil passing bolt	4
21	B6-14	GB1235-76	O ring 22 × 2.4	9
22	B6-18	XYQ3B.B-12	Longer adapter	1
23	B6-43	JB/ZQ4427-86	Hose adapter 10 II -600	2
24	B6-45	XYQ6B.B-18	Joint	2
25	B6-95	XYQ6B.B-11	Hex head bolt M12 × 80 × 30	2
26	B6-96	GB93-87	Spring washer 12	2
27	B6-62	XYQ6B.B-24(1)	Tong tail seat	1
28	B6-41	XYQ6B.B-17C	Rack plunger	1
29	B6-97	GB6710-86	Hex nut M12	2

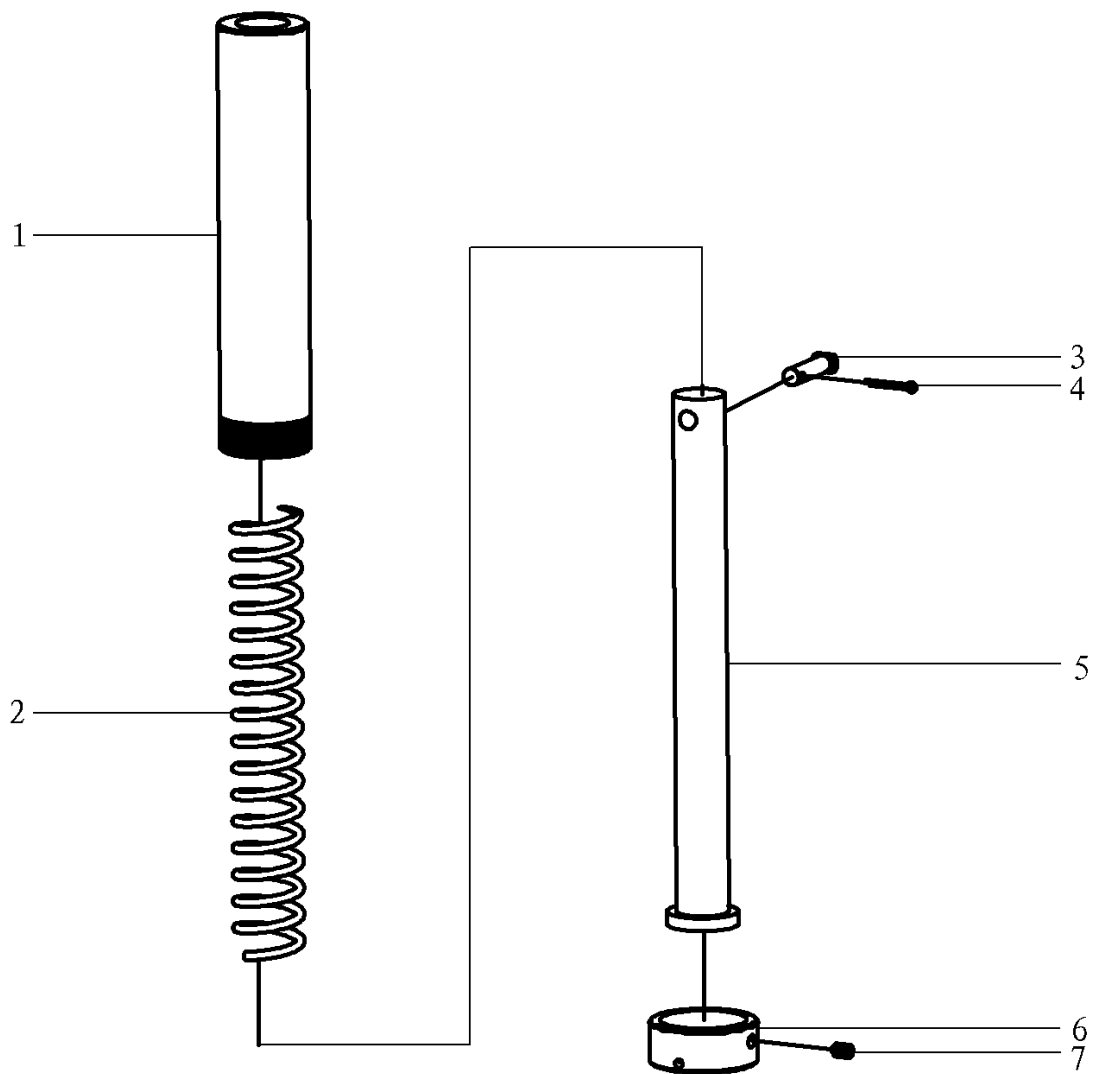

Fig. 15 Fore guide rod assembly

Item	Purchasing number	Part number	Part name	QTY
1	QD6-6	XYQ6B.QD.1	Fore guide rod assembl	2
2	QD6-8	XYQ6B.QD-2	Spring	2
3	3C4-5	XYQ3B.HD-5	Pin shaft	2
4	3C3-6	GB91-86	Cotter 2.5×20	2
5	QD6-10	XYQ6B.QD-1	Fore guide rod	2
6	QD6-11	XYQ6B.QD-4	End cover	2
7	QD6-12	GB71-85	Slotted cone end fastening screwM6×10-14H	2

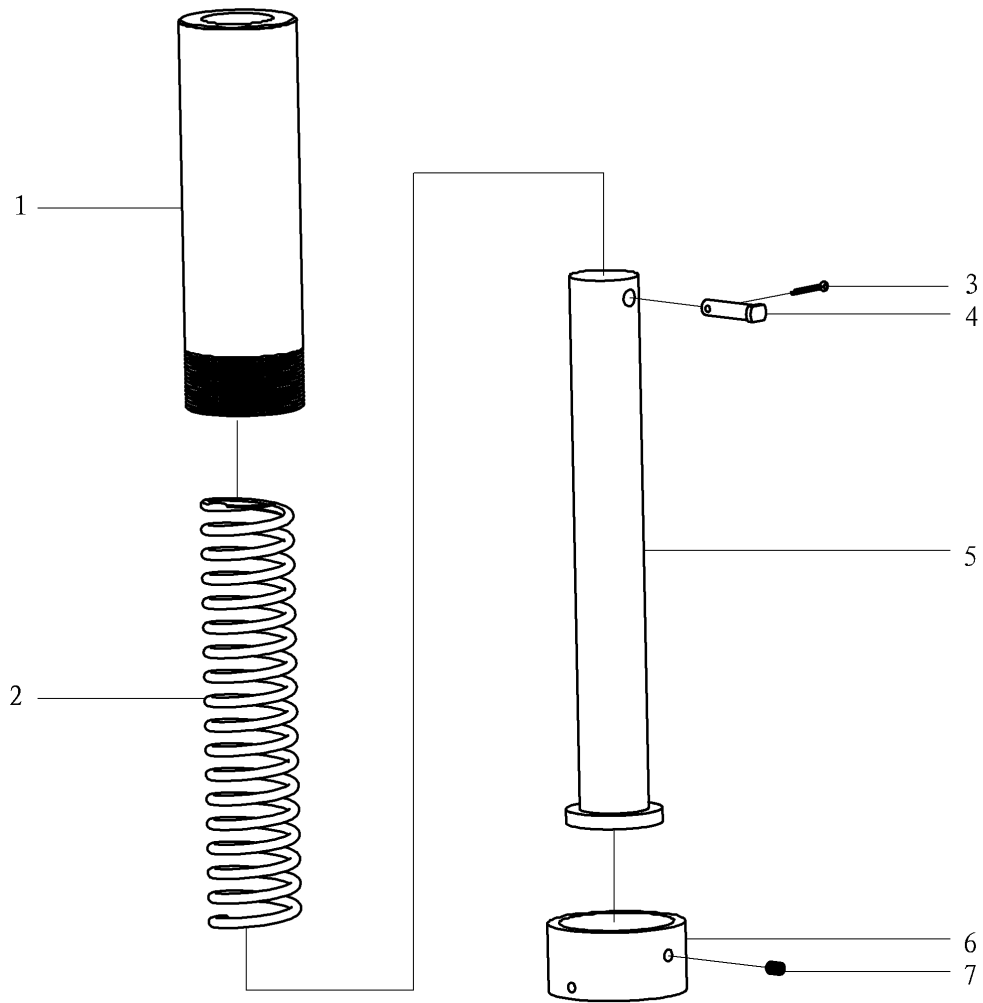

Fig. 16 Back guide rod assembly

Item	Purchasing number	Part number	Part name	QTY
1	HD6-7	XYQ6B.HD.1	Back guide rod assembly	1
2	HD6-8	XYQ6B.HD-3	Spring	1
3	HD6-10	GB91-86	Cotter 2.5×20	1
4	HD6-11	XYQ3C.HD-5	Pin shaft	1
5	HD6-12	XYQ6B.HD-1	Back guide rod	1
6	HD6-14	XYQ6B.HD-4	End cover	1
7	HD6-15	GB71-85	Slotted cone end fastening screwM6×10-14H	1

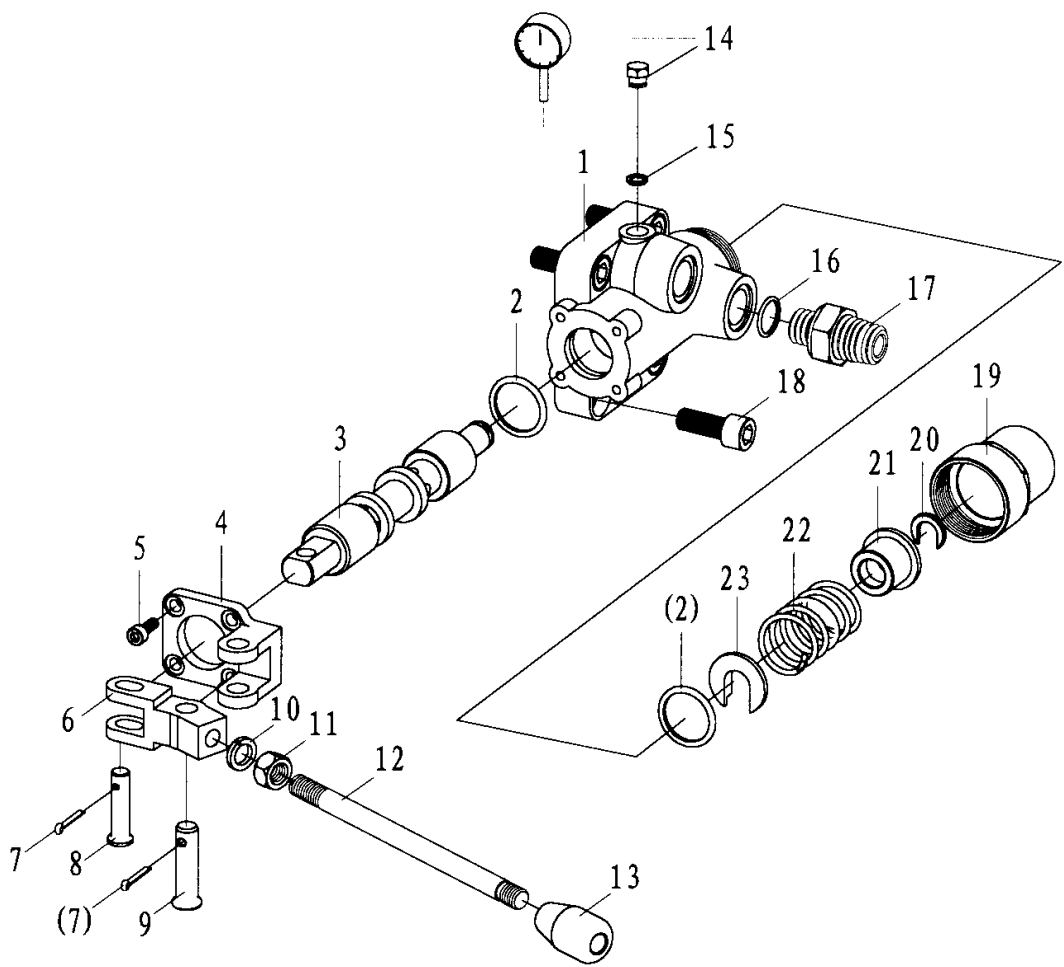

Fig. 17 Hand control valve

Item	Purchasing number	Part number	Part name	QTY
1	3C1-110	XYQ3C.Z.5-1	Valve body	1
2	3C1-113	GB1235-76	O ring 36×3.5	2
3	3C1-112	XYQ3C.Z.5.1	Combined vale spindle	1
4	3C1-119	XYQ3C.Z.5-7	Support seat	1
5	3C1-120	GB70-85	Hexagon socket head cap screw M6×16	4
6	3C1-122	XYQ3C.Z.5-8	Fork	1
7	3C1-144	GB91-86	Cotter 3.2×20	2
8	3C1-121	GB882-86	Pin B10×40	1
9	3C1-123	GB882-86	Pin B12×45	1
10	3C1-124	GB93-87	Spring washer 12	1
11	3C1-125	GB6170-86	Hex nut M12	1
12	3C1-126	XYQ3C.Z.5-9	Operating handle	1
13	3C1-127	XYQ3C.Z.5-10	Ball shaped handle	1
14	3C1-141	XYQ3C.Z.5-12	Plug	1
	3C1-142		Pressure gauge 0~16MPa	
15	3C1-143		Copper disc 14×2	1
16	Z6-63	GB1235-76	O ring 26×2.4	2
17	Z6-64	XYQ3B.Z-12	Adapter	2
18	3C1-111	GB70-85	Hexagon socket head cap screw M12×35	4
19	3C1-114	XYQ3C.Z.5-2	Valve tail seat	1
20	3C1-118	XYQ3C.Z.5-6	Circlip	1
21	3C1-117	XYQ3C.Z.5-5	Spring seat (2)	1
22	3C1-116	XYQ3C.Z.5-4	Spring	1
23	3C1-115	XYQ3C.Z.5-3	Spring seat(1)	1